

**AERIAL DEVICES**

**AEM** 

Association of  
Equipment Manufacturers



# **SAFETY MANUAL**

**FOR OPERATING AND MAINTENANCE PERSONNEL**

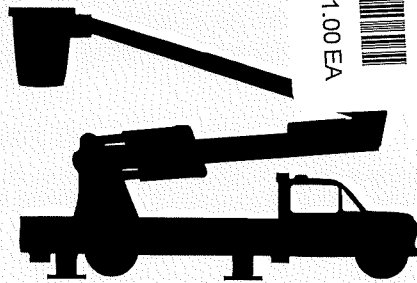

22085-00  
EMI Safety Manual- (Aeria  
HE210005



0391724

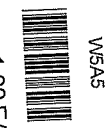

1.00 EA

BOX 0/1,430  
VMSAS

# Table of Contents

Acknowledgment.....	2
Safety Alert Symbol.....	3
Foreword .....	4
A Word to the User/Operator .....	5
Types of Aerial Lifting Devices .....	6
Safety - Before You Do Anything .....	8
Safety - Before Operation.....	13
Work Safely .....	21
Perform Maintenance Safely .....	33
Test Your Knowledge .....	47
A Final Word to the User.....	47

## Acknowledgment

We wish to thank the members of the Association of Equipment Manufacturers for their invaluable contributions in preparing this Safety Manual.

### NOTICE OF COPYRIGHT PROTECTION

Copyright 1998, by the Association of Equipment Manufacturers. All rights reserved. This work may not be reproduced or disseminated in whole or in part by any means without the prior written permission of the Association of Equipment Manufacturers.

ISBN 978-1-937029-26-5

Copyright ©1998 AEM (Association of Equipment Manufacturers)  
Revised 05/99, 08/03

# Safety Alerts

## Symbol

**This Safety Alert Symbol means ATTENTION! BECOME ALERT! YOUR SAFETY IS INVOLVED!**

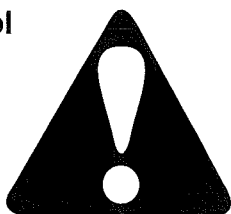

The Safety Alert Symbol identifies important safety messages on machines, safety signs, in manuals, or elsewhere. When you see this symbol, be alert to the possibility of personal injury or death. Follow the instructions in the safety message.

**Why is SAFETY important to You?**

## Signal Words

Signal words are distinctive words that will be found on the upper panel of safety signs on this machine and other equipment on the worksite. These words are intended to alert the viewer to the existence and relative degree of a hazard.



This signal word indicates an imminently hazardous situation which, if not avoided, will result in death or serious injury.



This signal word indicates a potentially hazardous situation which, if not avoided, could result in death or serious injury.



This signal word indicates a potentially hazardous situation exists which, if not avoided, may result in minor or moderate injury.

- ACCIDENTS DISABLE AND KILL
- ACCIDENTS COST
- ACCIDENTS CAN BE AVOIDED

## Foreword



This Safety Manual is intended to point out some of the basic safety situations which may be encountered during the normal operation and maintenance of your machine and to suggest possible ways of dealing with these conditions.

**This manual is NOT a substitute for the manufacturer's operating and maintenance manuals.**

Additional precautions may be necessary, or some instructions may not be applicable, depending on the equipment, attachment devices, and conditions at the worksite or in the service area. The manufacturer has no direct control over machine application, operation, inspection, lubrication, or maintenance. Therefore, it is YOUR responsibility to use good safety practices in these areas.

The information provided in this manual supplements the specific information about your machine that is contained in the manufacturer's manual(s). Other information which may affect the safe operation of your machine is contained on safety signs, or in insurance requirements, employer's safety programs, safety codes, local, state/provincial, and national laws, rules, and regulations.

**IMPORTANT:** IF YOU DO NOT HAVE THE MANUFACTURER'S MANUAL(S) FOR YOUR MACHINE, GET A REPLACEMENT MANUAL FROM YOUR EMPLOYER, EQUIPMENT DEALER, OR FROM THE MANUFACTURER OF YOUR MACHINE. KEEP THIS SAFETY MANUAL AND THE MANUFACTURER'S MANUAL(S) WITH THIS MACHINE.

## **A word to the user/operator**

It is YOUR responsibility to read and understand the safety manual and the manufacturer's manual(s) before operating this aerial device. This safety manual takes you step-by-step through your working day.

In reading this manual, you will note that any illustration depicting an unsafe work procedure or situation is labeled both with the words "wrong" and the mark of an "X" on the illustration. Each illustration is also numbered and the same number appears in the text at the end of the section that refers to the illustration.

While some of the illustrations appearing in this manual are in the nature of "cartoons," this approach

is intended solely as a means to promote your attention to the text. As noted repeatedly throughout this manual, AEM and its Manufacturers of Aerial Devices and Digger Derricks Council (MADDDC) are very serious about risks to human life and health caused by unsafe practices.

Remember that YOU are the key to safety. Good safety practices not only protect you but also protect the people around you. Study this manual and the manufacturer's manual(s) for your specific aerial device. Make them a working part of your safety program. Keep in mind that this safety manual is written only for vehicle mounted aerial devices. Practice all other usual and customary safe working precautions, and above all—

**REMEMBER—SAFETY IS UP TO  
YOU  
YOU CAN PREVENT SERIOUS INJURY OR DEATH**

## Types of aerial devices

There are two basic types of aerial devices:

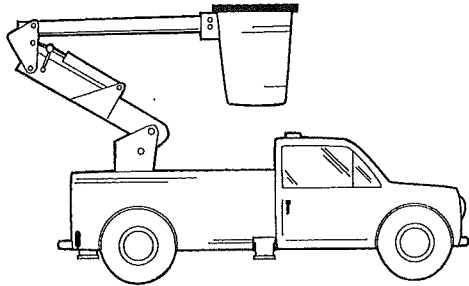

Articulated Boom Aerial Devices (insulated or non-insulated)

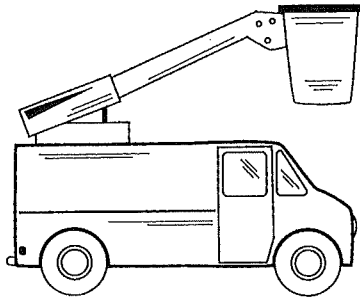

Extendible (telescopic) Boom Aerial Devices (insulated or non-insulated)

## Types of aerial devices

There are also hybrid aerial devices which are essentially articulated aerial devices with extendible (telescopic) booms.

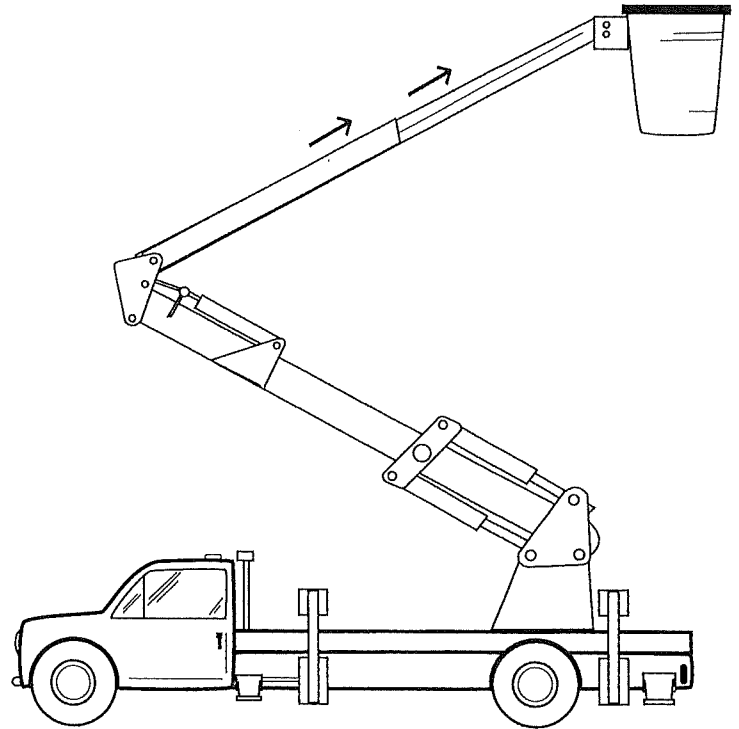
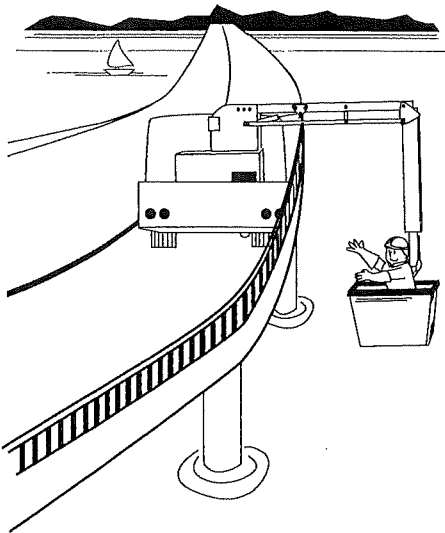

# Safety - before you do anything

## For Safe Operation



**WARNING:** For safe operation of this aerial device, all members of the crew must be qualified and authorized to perform their particular duties. (2)

To be qualified, you must:

- understand the written instructions supplied by the manufacturer, company rules, and OSHA regulations;
- have training, including actual operation of this aerial device;
- know and follow the safety rules and regulations for the jobsite.



**WARNING:** Use of this machine by an untrained person can result in severe injury or death.



**WARNING:** On the job, you and your crew must not use drugs or alcohol; they can impair alertness and coordination. Anyone taking prescription or over-the-counter drugs needs medical advice regarding whether or not they can safely operate machines.

The ground crew member must know how to lower the unit from the lower controls and emergency rescue procedures.

## Know The Rules (2)

Most employers have rules governing operation and maintenance of equipment. Before you start work at a new location, check with your supervisor or the safety coordinator. Ask about rules you will be expected to obey.

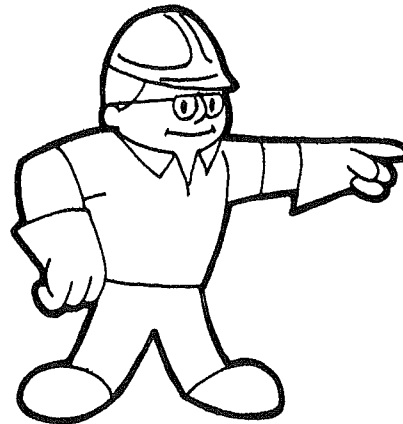

2  
RIGHT

# Safety - before you do anything

- Inspect your aerial device each day, following the manufacturer's guidelines set forth in the manuals for this equipment, including all boom and stabilizer functions before beginning work (use lower controls).
  - Know the capacity and operating characteristics of this machine, including maximum permitted ground slope.
  - Do not overload the boom system or platform.
  - Know the weight of items to be lifted. (See page 31 "Lifting Loads With An Aerial Device".)
  - Never remove any part of the aerial device (except for service).
  - If your aerial device is insulated, keep the insulated part of the booms clean, dry and free of oil or grease.
  - Never modify any part of the aerial device without manufacturer's permission.
  - Latch platform door (if equipped).
  - Securely fasten any safety chains across door openings (if equipped).
  - Fasten your fall protection device to the anchor point before you start.
  - Never allow unauthorized riders on your aerial device.
  - Keep others away from vehicle with boom in operation.
  - Electrically ground the vehicle (if applicable).
  - Maintain specified distances from electric power lines and apparatus.
  - Use insulated shields, covers, mats when required.
  - Never use non-insulated aerial devices near power lines.
  - Do not use an aerial device to lift equipment or pull cable unless it is specifically designed and rated for such loads.
  - Wear your insulated gloves and sleeves when required.
  - Alert crew members when lowering outriggers.
  - Use outrigger pads (when applicable).
  - Communicate with crew members when aloft in platform.
  - Use intercom (if applicable).
  - Discuss your work plans prior to performing job.
  - Wear your insulated hard hat.
  - Use vehicle barrier kit.
  - Whenever you leave your aerial devices unattended, always lower the boom and platform or other attachments to their transport position. Engage the parking brake, stop the engine, and remove the key.
  - Know when the next insulating dielectric test for the unit is due, and do not operate the unit if the test has not been performed.
  - Understand hand, flag and horn signals.
- Make sure you understand the rules covering traffic at your jobsite. Know what all signs, flags, and markings mean. Know when to use lights, turn signals, flashers, and horns.

**Know and understand the rules.**

# Safety - before you do anything

## Protect Yourself

**Wear or use all the protective clothing and personal safety devices issued to you or called for by job conditions. You must always use fall protection.**

You may also need:

- Safety belt or harness and lanyard
- An insulated hard hat
- Safety shoes
- First aid kit
- Safety glasses, goggles, or face shield
- Insulated gloves, sleeves
- Insulated shields, covers, mats and blankets
- Insulated tools
- Wet weather gear
- Cotton clothing

Wear whatever is needed, don't take chances. (3)



**WARNING:** Do NOT wear loose clothing, neckties, rings, watches, bracelets or chains. Wrapping or entanglement can result in severe injury or death.

**3  
RIGHT**

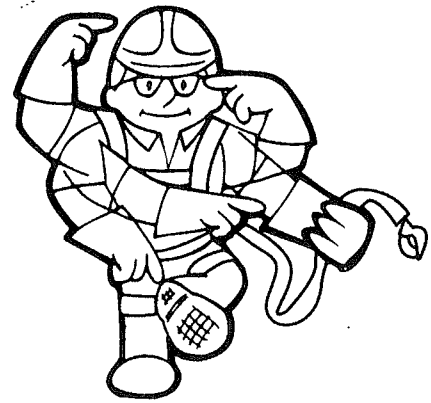

# Safety - before you do anything

## Be Alert!

Know where and how to get assistance. Know how to use a first aid kit and fire extinguisher/fire suppression system and be certain these items are available and easy to get to. Know CPR. (4)

## Be Aware!

Take advantage of training programs offered.

## Be Careful!

Human error is caused by many factors: carelessness, rushing to get a job done quickly, fatigue, overload, preoccupation, drugs, and alcohol to name a few. Damage to the aerial device can be fixed in a short period of time, but serious injury or death has a devastating effect. For your safety and the safety of others, encourage your fellow workers to act safely. Do not force or overextend yourself beyond your capabilities based on training and experience. Use the proper tool for the job at hand. Do not use tools and equipment beyond their design capabilities.

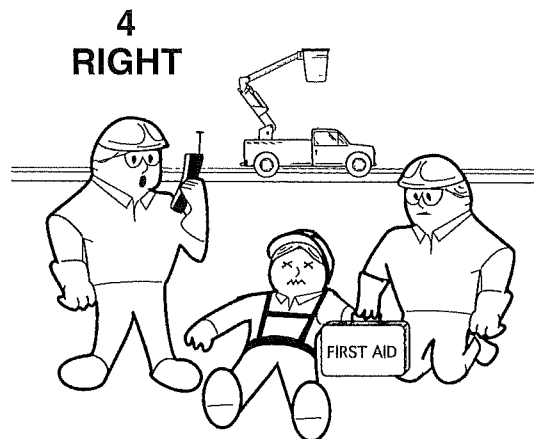

Play it safe. Know how to summon help.

# Safety - before you do anything

## Know Your Equipment

Aerial devices differ in their operation, capacity, mechanisms, maintenance, intended uses, etc., so your knowledge of one aerial device may not help you safely operate another.

Know your aerial device. Know how to operate all equipment on your aerial device. Know the purpose of all the controls, gauges, warning labels and indicators. Know the rated load capacity, speed range, braking and steering characteristics, turning radius, operating clearances, and ground slope limits. Keep in mind that rain, snow, ice, wind, loose gravel, soft ground, slope, etc., change the operating capabilities of your aerial device. Study the DANGER, WARNING, and CAUTION safety signs on your aerial device and all DANGER, WARNING, CAUTION and INFORMATION notes in the operator's manual.

STUDY THE MANUFACTURER'S OPERATOR'S MANUAL BEFORE OPERATING THE AERIAL DEVICE. IF THERE IS NO MANUAL WITH THE AERIAL DEVICE— GET ONE. STUDY IT BEFORE YOU START WORK. (5)

IF THERE IS SOMETHING IN THE MANUAL YOU DON'T UNDERSTAND, ASK YOUR SUPERVISOR TO EXPLAIN IT TO YOU.

**ATTENTION:** This manual covers safe practices for Aerial Devices. If your aerial device is equipped with other devices or special accessories, read the manufacturer's operating and safety manuals pertaining to that equipment before using it.



**5  
RIGHT**

# Safety before operation

## Check The Safety Equipment

To protect you and others around you, see that applicable safety equipment is securely in place and in operating condition. Make certain all guards, railings, covers and safety signs are installed on the aerial device and vehicle as required by the manufacturer. (6)

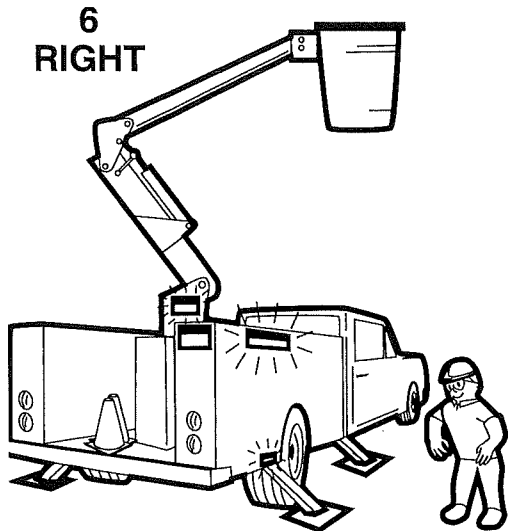

- Platform liner
- Platform door latch
- Fall protection device
- Safety chains across door openings (if equipped)
- Emergency controls
- Ground controls
- Intercom
- Interlock devices
- Barricade or barrier kits for vehicle
- Deadman control
- Outrigger pads (if applicable)
- Wheel chocks
- Upper and/or lower boom latches
- Warning lights
- Safety signs
- Guards
- Insulated shields, covers and mats
- Back-up alarm
- Fire extinguisher/fire suppression system
- First aid kit
- Ground equipment

Use them! Never remove or disconnect any safety device.

Play it safe. Take advantage of all the protection available.

# Safety before operation

## Check The Aerial Device

Before you begin your workday, you should inspect your aerial device and have all systems in good operational condition as set forth in the manufacturer's manual. Do not operate the aerial device until all deficiencies are corrected by a qualified individual.

- Do pre-travel inspection test.
  - Check for broken, missing or damaged parts. Have a qualified person make the necessary repairs. (7)
  - Check the tires for cuts, bulges and correct pressure.
  - Replace badly worn or damaged tires; properly inflate tires.
  - Check the outriggers, if so equipped, or other stabilization equipment such as torsion bars.
  - Check service, parking, and swing brake for proper operation.
  - Check the boom, platform, rotation, rotation brake and boom winch operation (if so equipped) at both upper and lower controls.
- Check the hydraulic system. Repair any leaks. If the outriggers have crept down overnight, test check valve system.
  - Ensure that regular lubrication is performed in accordance with the manufacturer's guidelines.
  - Check cooling system.
  - Check the electrical systems and components for deterioration or wear including those not readily visible on a frequent inspection.

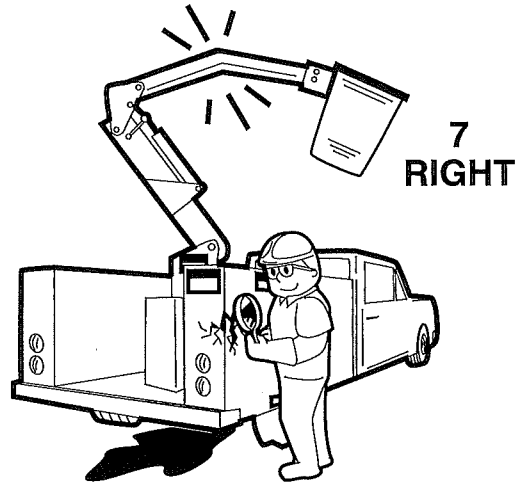

## Safety before operation

- Check bolts and fasteners for proper tightness and signs of wear.
- Examine welds for cracks or signs of rust, which can indicate potential problems.
- Check platform door latch for proper operation.
- If the boom is insulated, check insulation components to be certain they are dry and free of grease, oil, or dirt.
- Perform all maintenance procedures outlined by the manufacturer of your aerial device.

Refer to pages 9 and 13.



**WARNING:** Diesel fuel or hydraulic fluid under pressure can penetrate the skin or eyes and cause serious injury, blindness or death. Fluid leaks under pressure may not be visible. Use a piece of cardboard or wood to find leaks but do not use your bare hand. (8) Wear a face shield or safety goggles for eye protection. If any fluid is injected into the skin, it must be surgically removed within a few hours by a doctor familiar with this type of injury.

**Don't let fluids get under your skin.**

# Safety before operation

## Perform Pre-Operation Inspection

Inspection of the aerial equipment prior to use is a **MUST**. It cannot be assumed that the last crew to use the unit left it in good order. The pre-operation inspection is the time to detect potential failures and take corrective action before a minor defect becomes a major breakdown, or worse, results in injury or death to personnel. Use the checklist provided for that purpose in the Manufacturer's Operator's Manual, which may include the following: (9)

- Outriggers (if so equipped) and booms for possible structural cracks.
- Control handles for free operation.
- Booms at pivot points.
- Fiberglass boom (if so equipped) for visible damage and cleanliness.
- Bolts and nuts.
- Hydraulic cylinders and attachment points for leaks.
- Platform at attachment points.
- Availability of fall protection device, wheel chocks and outrigger pads.
- Platform door latch for proper operation.
- Safety chains for secure clasp.
- Welds for cracks or signs of rust, which can indicate potential problems.
- Electrical apparatus for malfunction and cleanliness.

- Visual and audible safety devices for malfunction.
- Do not use an aerial device that is not in proper operating condition.

It is the **OPERATOR'S RESPONSIBILITY** to run the check of all functions and controls before going aloft.

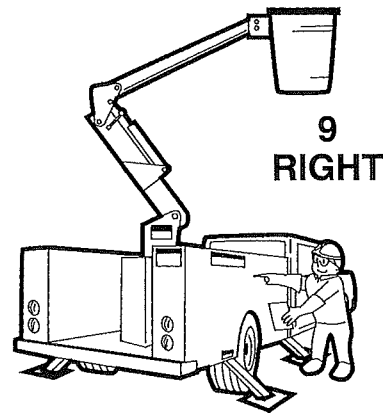

**WARNING:** Be certain that all the decals are

- in place
- legible
- understood.

# Safety before operation

## Use Caution When Fueling



**WARNING:** Never fill the fuel tank when the engine is running, while you're smoking or when the truck is near an open flame. Never overfill the tank or spill fuel. If fuel is spilled, clean it up immediately.

Ground the fuel funnel or nozzle against the filler neck to prevent sparks and be sure to replace the fuel tank cap. For additional information on fire hazards, refer to the section on Fire and Explosion Hazards.

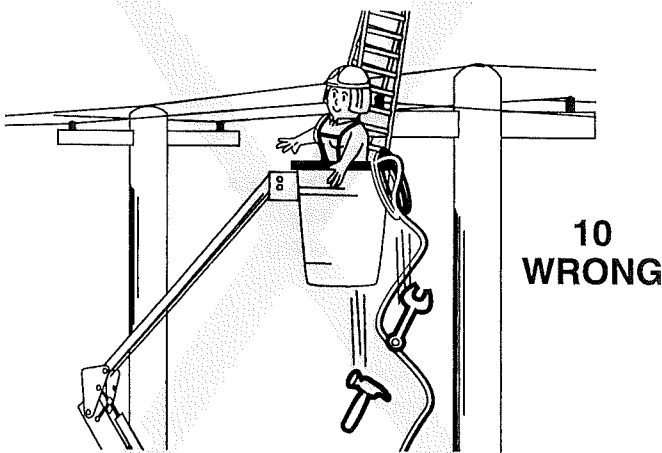

Dirt, grease and moisture decrease insulation protection.

## Clean Up

Make sure the operator's area, lift, platform, truck bed, steps and hand holds are clean and free of debris. Oil, grease, snow, ice or mud in these areas can cause you to slip and fall. Clean your boots of excess mud before getting on the machine.

Remove all loose personal items or other objects from the truck cab and operator's area on the aerial device. Secure these items in the tool box or remove them from the machine. (10)



**WARNING:** If the aerial device is insulated, the insulated portions of the aerial device **MUST** be dry and free of grease or oil to maintain maximum insulation protection.



**WARNING:** Dirt, grease, other foreign matter, moisture, and humidity will all dramatically increase the conductivity of synthetic rope.

# Safety before operation

## Safe Transport

While traveling on public roads or streets, be sure all local and state/provincial laws and regulations are followed.

Refer to your manufacturer's manual for instructions on preparing the unit for transport. Secure the boom and platform in the transport position. Make sure that outriggers are up and secured in the transport position. Make sure that all accessory equipment is properly stored and secure. (11)

When driving at night, use appropriate lights. Make sure you know your machine travel height and the height of all underpasses.

Always use hazard warning lights when parked at a job-site. Never park in traffic areas.

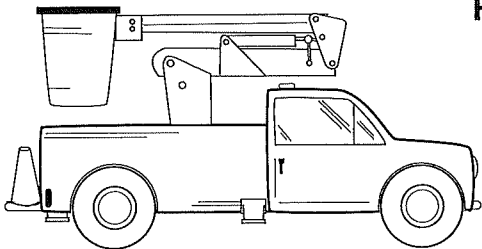

**11  
RIGHT**

## Know The Working Area





**WARNING:** Failure to properly evaluate the work area can lead to serious injury or death.

Learn—beforehand—as much about your working area as possible. Check for:

- Exact location of any overhead electrical, telephone, TV cable, or other utility lines.
- Location of slopes. Follow manufacturer's maximum slope lift can operate on.
- Potholes
- Broken curbs
- Open trenches
- Dropoffs or overhangs
- Soil conditions (soft or hard)
- Standing water and marshy areas
- Rocks, stumps and tall grass
- Overhead or side obstructions
- Conditions of roads
- Mud, snow or ice
- Heavy traffic
- Underground structures
- Thick dust, smoke, fog

## Safety before operation

 **DANGER:** Never approach any power line with any part of your machine unless all local, State/Provincial, company work rules and Federal (OSHA) required safety precautions have been taken. Use extreme caution; serious injury or death will result with contact from any power line.

 **DANGER:** DO NOT maneuver machine or personnel inside PROHIBITED ZONE. (12) Allow for sway, drift, and platform movement in calculating safe distances.

ASSUME all electrical parts and wiring are ENERGIZED unless known otherwise.

Always follow State/Provincial, company work rules and Federal (OSHA) standards.

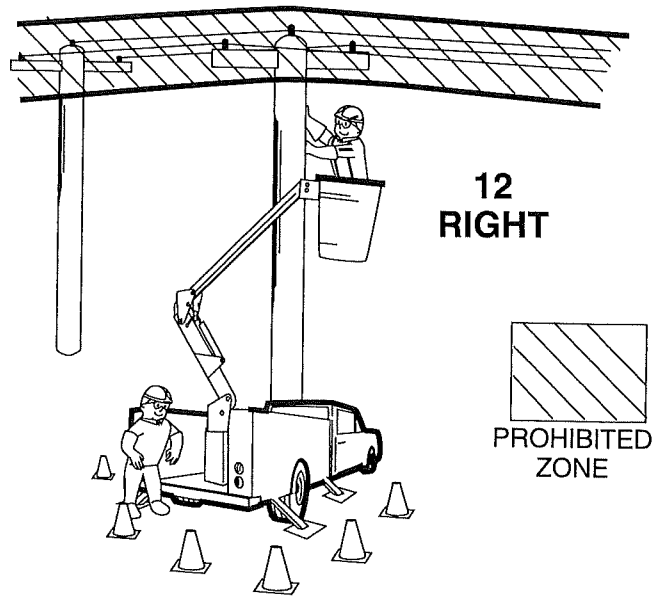

You must know your electrical safety zones.

# Safety before operation

## Before Starting

Before starting, walk around the equipment. Make sure no one is under, on or close to the unit. Let other workers or bystanders know you are starting up. Don't start until everyone is clear of the unit. (13)

When operating an aerial device inside a building, know what clearances you will encounter—overhead, doorway, aisles, etc.; also the weight limitations of floors and ramps. Make sure there is sufficient ventilation for inside operation.

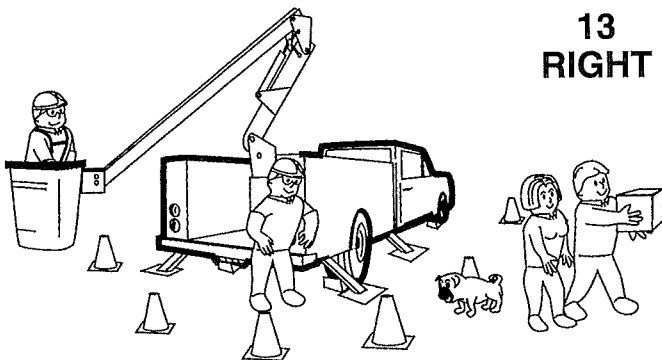

## Position Unit For Operation

1. Position vehicle on the most level ground, but the equipment must not be operated on an incline greater than as permitted in the manufacturer's operations manual. If on an incline, position the vehicle so that the platform would be operated on the upgrade side in a stable position.
2. Set the brakes.
3. Use wheel chocks (both sides).
4. Engage power source.
5. Set the outriggers (if so equipped). Use outrigger pads if ground is soft. Level the vehicle as much as possible, but observe manufacturer's maximum ground slope.
6. Spot your vehicle as close to the work as possible to minimize reach, but be sure there are no obstructions to prevent safe and proper lift and rotation.
7. Make sure the vehicle is stable.

# Work safely

## Remember These Rules

When operating the boom(s):

- Keep your fall protection device fastened and comfortably snug. (14)
- Securely fasten any safety chain (if equipped).
- Use your personal protective equipment.
- Be in control of your aerial device at all times.
- Look and listen for malfunctions.
- Stop if a malfunction or erratic operation is detected.
- Correct or report trouble immediately.
- Keep both feet on the floor of the platform.
- Know your clearances.

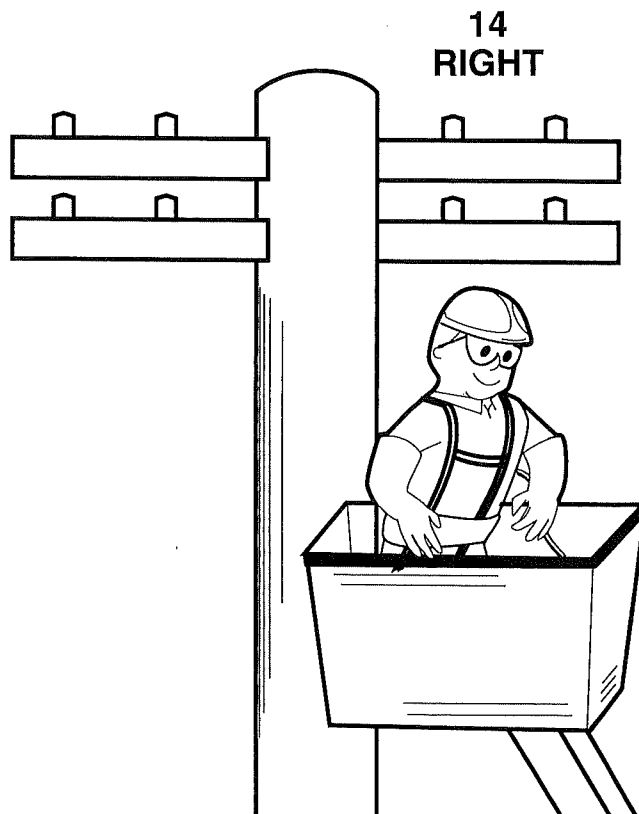

Keep yourself safe and secure.

# Work safely

## Remember The Other Person

- Never allow an untrained or unqualified person to operate your aerial device. Handled improperly, this aerial device can cause severe injury or death.
- Know the pinch points and moving parts on the aerial device. Awareness on your part can prevent accidents.
- When traveling, never allow anyone to ride on the back of the truck or in the lift platform.

## Aerial Device Safety Precautions

- Never allow the booms or turntable to enter traffic lanes without proper barricading. Exercise extreme care, especially with articulating boom and/or large offset turntable while rotating. Park to block traffic.
- Check the clearance overhead. Note any obstructions. Know exactly how much clearance all parts of your aerial device have around electric power lines.

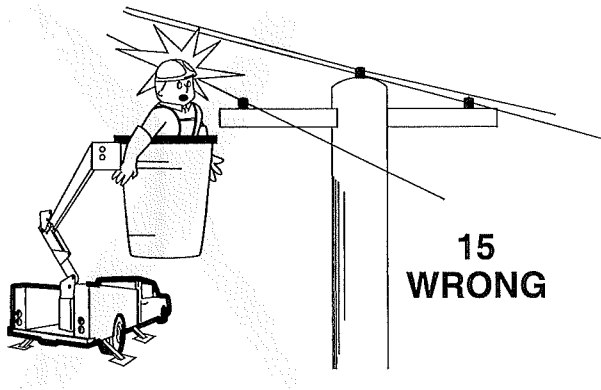

**DANGER: NON-INSULATED** machines shall **NOT** be used on or near any energized power line. Death or serious injury will result from contact or inadequate clearance to energized electrical power lines or apparatus. (15)

## Work safely

- MAINTAIN SPECIFIED DISTANCE FROM ELECTRICAL LINES AND APPARATUS. Never approach power lines with any part of your machine unless all local, state/provincial and federal (OSHA) required safety precautions have been taken. Use extreme caution.
- YOU MUST ALLOW FOR PLATFORM SWAY, ROCK AND CREEP, ALSO ELECTRICAL LINE SWAYING.
- Ground personnel must not contact the vehicle when the unit is working on energized power lines. (16)
- Beware of strong and/or gusty wind conditions.
- Set brakes and chock the wheels before operating.
- Make sure the area is clear of all persons before you start operating.
- As necessary, use a signal person to control traffic.
- Keep yourself and others away from the outriggers when they are being operated.
- Always have outriggers in view when they are being extended, and/or use a signal person to watch.
- Always make sure that you follow the manufacturer's recommendations while operating the aerial device.

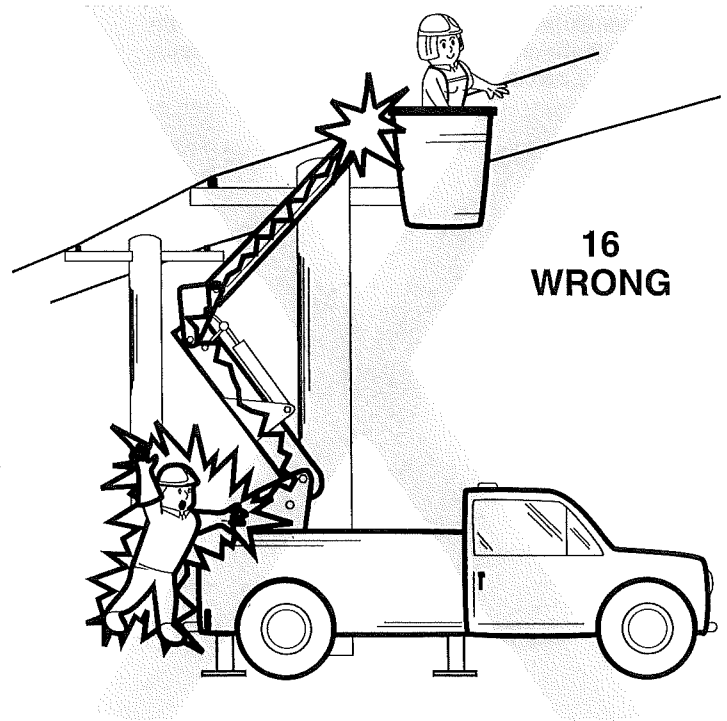

Keep your distance from power lines.

# Work safely



**WARNING:** Never allow anyone else to enter aerial device's rotation area or walk under the platform or suspended load. Death or serious injury can result. (17)

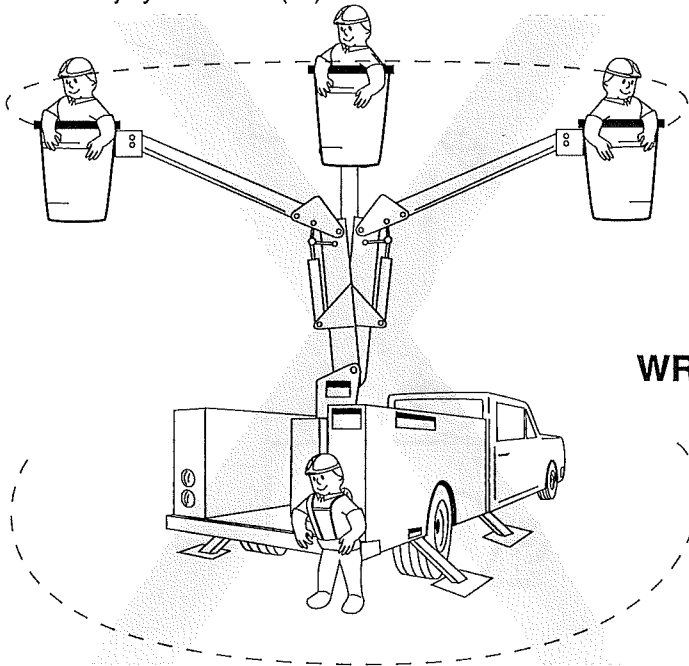

## Repositioning Vehicle

If your machine has a separate power source to operate the lifting and rotation functions, shut off the vehicle engine and remove key. Before moving the vehicle, stow the boom and platform in the transport position and secure if required, raise the outriggers (if so equipped), remove the wheel chocks, disengage PTO, and then drive the machine forward or backwards, as required. After the machine has been repositioned, engage the parking brake, chock the wheels, and shift transmission controls to neutral or to gear for PTO operation. Lower the outriggers and level the machine.

**17  
WRONG**

# Work safely

## Utilities – Overhead

Electrocution can result from contacting or approaching overhead power cables. Only INSULATED machines are suitable for this work.



**DANGER:** An insulated platform provides no protection from contact between two energized conductors or between an energized conductor and a grounded conductor by the operator, even with insulated machines. (18)



**DANGER:** Never pass platforms between power lines, even with insulated machines. (18)



**DANGER:** With an insulated machine, never approach overhead power lines with any part of your machine unless all local, state/provincial, company work rules and federal (OSHA) required safety precautions have been taken. Use extreme caution. YOU MUST ALLOW FOR PLATFORM SWAY, ROCKING AND CREEP, AS WELL AS ELECTRICAL LINE SWAYING.

Check overhead clearances: Know your margin of safety. If possible, have power to the lines disconnected. If not possible, request a signal person for guidance to maintain at least minimum distance required by OSHA from overhead power lines.

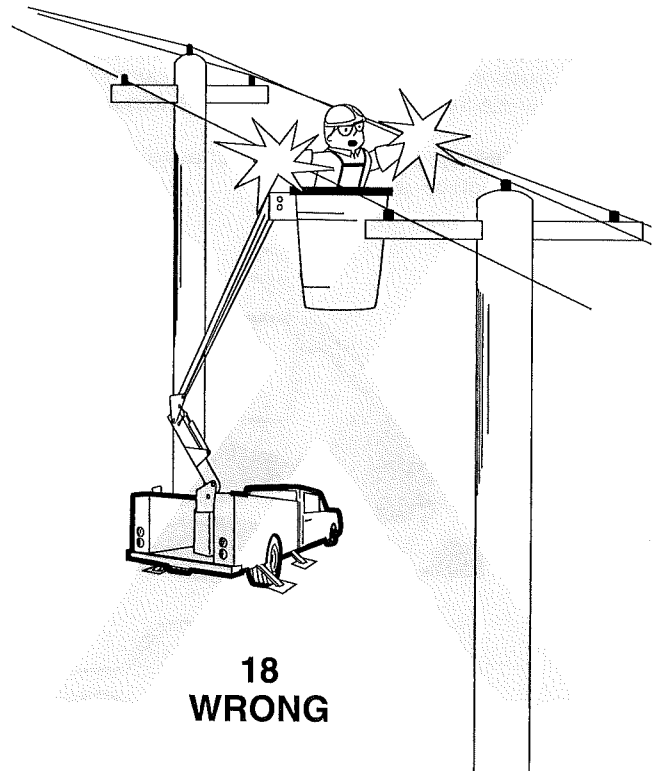

Inadequate clearance can be fatal.

## Work safely



**DANGER:** Contact with energized power lines will cause DEATH or serious injury to persons in the platform and those on the ground in contact with the machine. Maintain adequate clearance.



**WARNING:** Do not operate your aerial device during electrical storms. (19)



**WARNING:** Your platform and platform liner, synthetic winch cable and insulated boom section must be dry and clean before operating your aerial device on or near power lines and apparatus. Moisture, grease and debris will defeat the insulating value of these components, which could result in serious injury or death.



**WARNING:** DO NOT drill drain holes in insulated platform or platform liners.

**19  
WRONG**

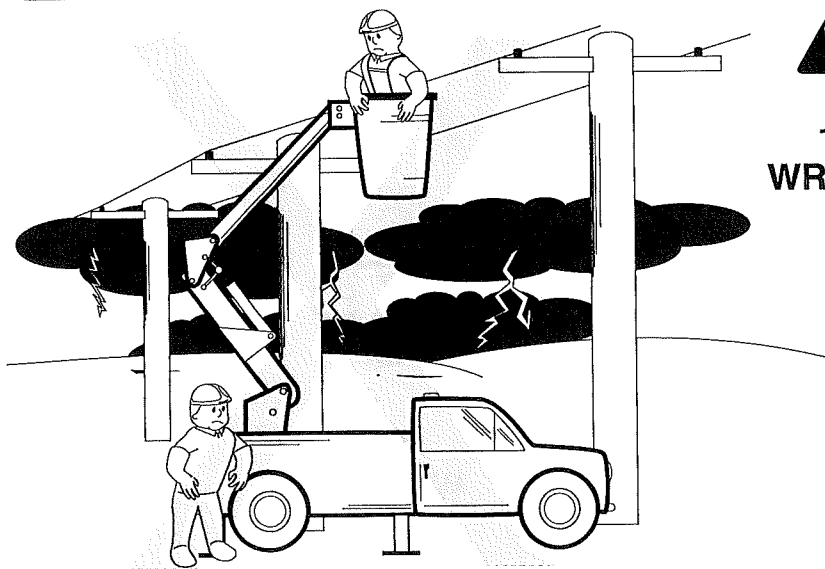

## Work safely



**DANGER:** NO AERIAL DEVICE, WHETHER INSULATED OR NOT, PROVIDES ANY ELECTRICAL PROTECTION TO ANY OCCUPANT OF THE PLATFORM IF THERE IS PHASE-TO-PHASE OR PHASE-TO-GROUND CONTACT. SUCH CONTACT WILL CAUSE SEVERE INJURY OR DEATH. (20)



**DANGER:** Contact can be made when any portion of the boom tip is in contact with a phase or ground and the operator is in contact with another phase or ground and contact is made with any area of the boom tip by the operator. Contact will cause severe injury or death.

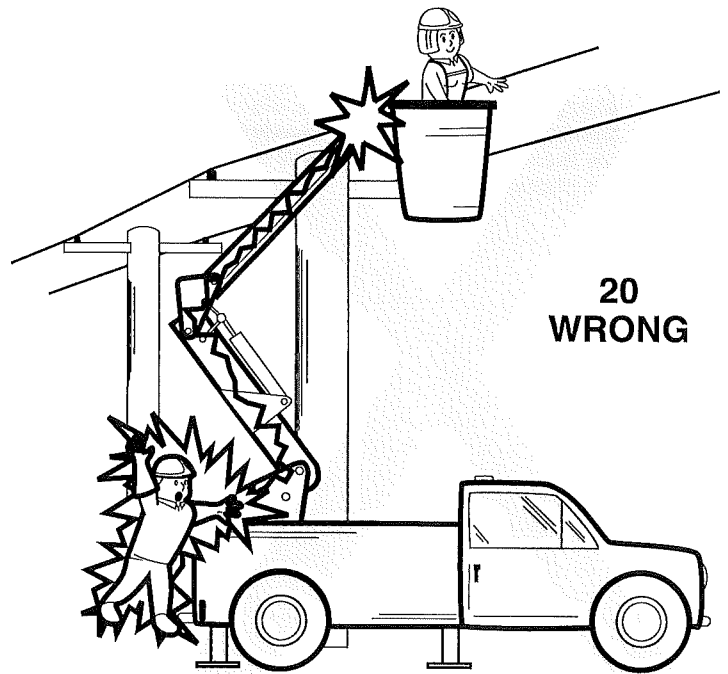

Contact with energized power lines can cause DEATH.

## Work safely



**WARNING:** In case of an accident, or other emergency, involving any electrical source. **DO NOT** approach or enter the vehicle unless you are certain the vehicle is **NOT** energized. If the vehicle is energized, or you are not sure, stand on insulated pad or blanket, use a long insulated pole to operate the emergency/lower control system to bring the platform down. (21)

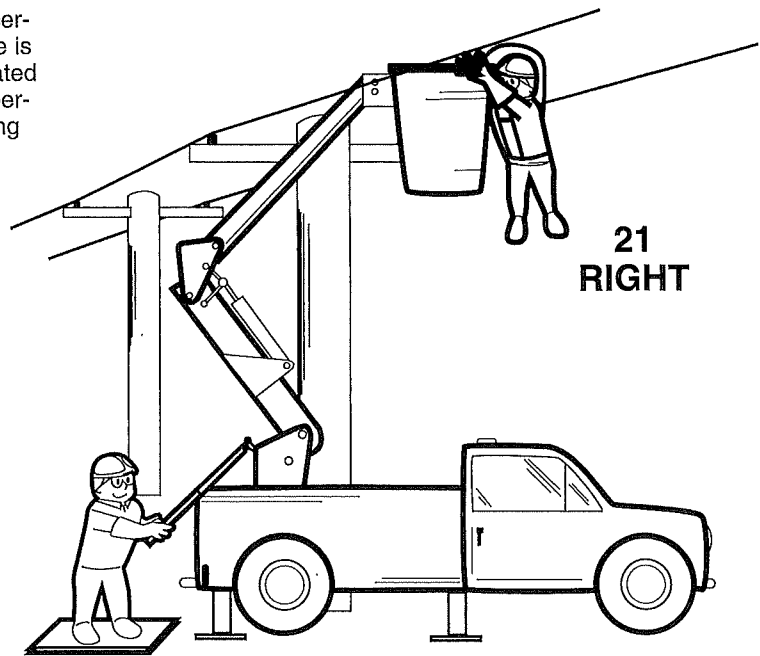

# Work safely

## Aerial Device Operation



**WARNING:** You must wear the fall protection device. Before raising the platform, attach the lanyard to an anchor point.



**WARNING:** Never allow anyone to tamper with, service, or operate an aerial device from the lower control station while personnel are in the platform, except in an emergency or equipment malfunction. Move the controls smoothly. For final positioning of the platform, gently “feather” the controls.



**WARNING:** Jerking the controls will cause sudden starts and stops in aerial device operation. This can cause damaging shock loads and/or cause the platform to sway violently. When the platform has been raised to the working position, be extremely cautious to prevent any objects from striking or interfering with the operating controls. Secure all tools, equipment or other materials placed on the platform to keep them from shifting or falling. (22)

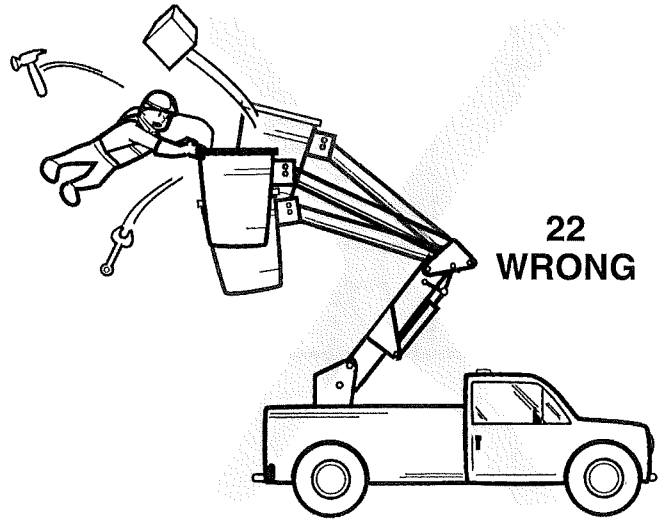

Position the platform with a “feathering” touch.

## Work safely



**WARNING:** Never disconnect your fall protection device while aloft. Any sudden machine movement can cause you to fall from the platform. (23)



**WARNING:** Never use ladders, planks, steps or other devices to provide additional reach or gain greater height. Do not lean over or sit or climb on the platform railing. Always keep both feet on the platform floor at all times.

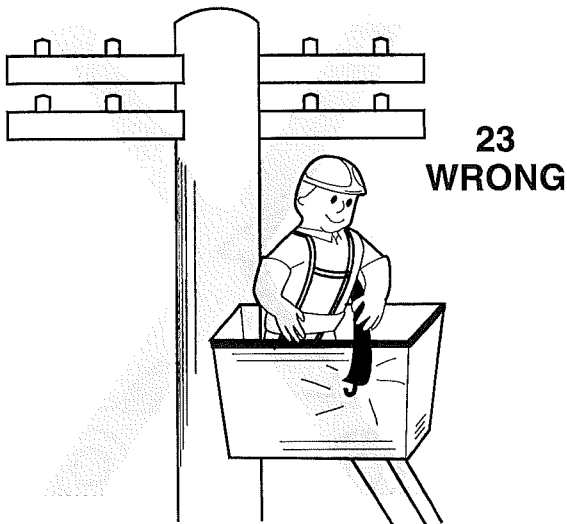

**WARNING:** Never belt off to an adjacent pole, tree or other structure when working from an aerial platform. (24)



**WARNING:** Never attempt to transfer from the platform to a pole, tower, tree or any adjacent structure while the booms are in a raised position.



**WARNING:** On non-overcenter machine, do not attempt to readjust the boom safety stops for more reach. When raising, lowering or rotating the platform, use extreme caution. Always look in the direction of movement. Watch out for obstructions above, below and to all sides. If necessary, use a signal person on the ground to guide you.



# Work safely

## Lifting Loads With An Aerial Device

Do not use an aerial device to lift loads unless the aerial device has been specifically designed and equipped with attachments for material handling. Understand the lifting capabilities of the boom and jib winch package.

Before lifting a load, see the manufacturer's manual or load chart affixed to the boom for the lifting capacity of your machine with the boom in various positions. (25)  
Lift loads only if designed and equipped with attachments for material handling.

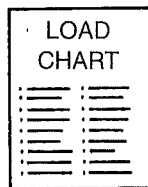
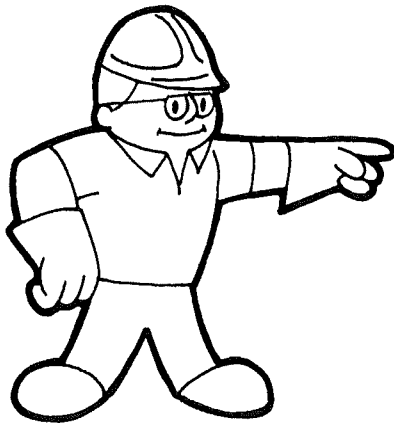

**25  
RIGHT**



**WARNING: OVERLOADING IS DANGEROUS.** Know the weight you are lifting. If you do not know the weight, you must determine its weight before lifting load. Make certain you are within the safe load and work radius limitations of this aerial device and are on solid level ground within manufacturer's maximum slope before lifting any load. Never attempt to lift an object at an angle. The boom head must be directly over the load before lifting. Always lower the outriggers to the ground before lifting. If ground is soft, place flotation pads under each outrigger. When lifting, be sure the load is properly balanced. Move slowly so the load does not sway or swing around. If necessary, use a tag line for additional control. Avoid shock to loads when lowering a load. Lower slowly and smoothly. **DO NOT** attempt to pull a pole from the ground with your aerial device. Use a pole puller. **DO NOT** attempt to pull cable. This creates abnormal stresses in the booms, which can lead to pin failure and boom collapse.

Don't overload your machine. Know your machine's lifting capacity.

## Work safely



**WARNING:** Never tie a load to the platform or boom. The platform may bounce or sway violently when the load falls. Only use lifting device provided.



**WARNING:** Allow extra overhead clearance in case boom does raise when load is relieved.



**WARNING:** Boom mounted material handling devices are for lifting freely suspended loads only. Never side load the boom. (26)

### Stowing The Unit

1. Gently settle the boom(s) onto supports using a “feathering” movement of the controls.
2. Secure the boom(s) in the supports per manufacturer’s instructions. (27)
3. Raise the outriggers (if so equipped) to their full “up” travel position.
4. Disengage the PTO.
5. Stop the engine.

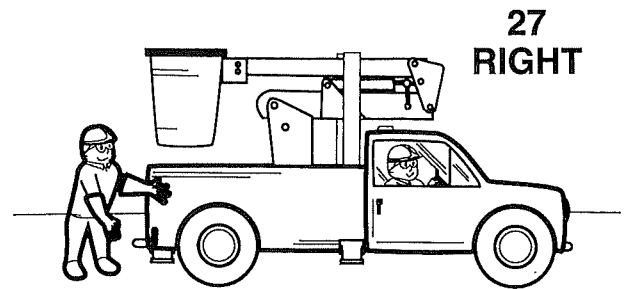
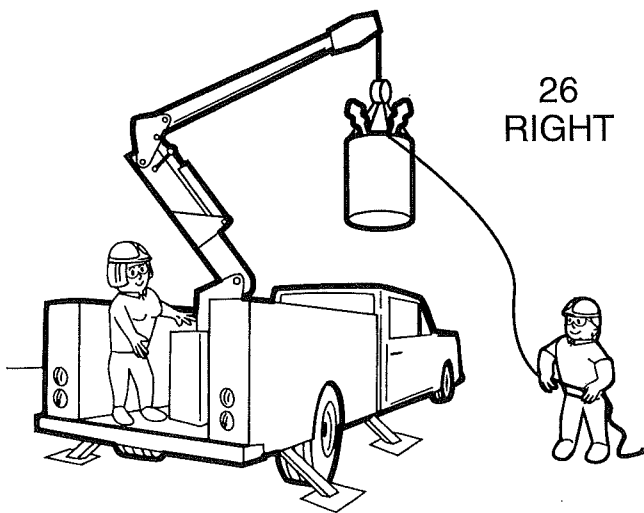

# Perform maintenance safely

Proper maintenance is necessary to provide safe, reliable operation of the aerial device.

Be certain that the aerial device you are operating has been properly maintained by qualified personnel. Read and understand the manufacturer's manual(s) pertaining to your equipment. Perform all operator's inspections required by the manuals and or federal, local, or state/provincial regulations.

 **WARNING:** Do not perform any work on a machine unless you are authorized—and qualified—to do so.

Use parts, lubricants and service techniques recommended by the manufacturer.

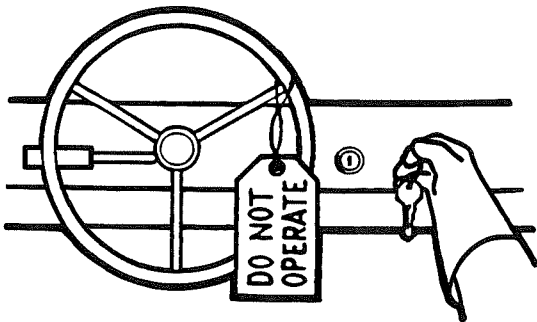

**28  
RIGHT**

## Definition Of Qualified Individual:

A "Qualified Individual" is defined as a person who, by possession of a recognized degree, certificate, professional standing, or skill, and who, by knowledge, training, and experience, has demonstrated the ability to deal with problems relating to the subject matter, the work, or the project.

If you have been authorized to do maintenance, READ AND UNDERSTAND THE MANUFACTURER'S SERVICE AND OPERATOR'S MANUALS. Study the instructions; check the lubrication charts; examine all the instruction and warning messages on the machine for readability. Maintenance can be dangerous unless performed properly. Be sure you have the necessary skill, information, correct tools and equipment to do the job correctly. Use manufacturer's recommended hydraulic oil.

Attach a "**DO NOT OPERATE**" tag or similar warning tag to the starter switch or steering controls before performing maintenance on the machine.

If the machine should not be started, remove the ignition key. (28)

If you don't know what you're doing—don't do it.

# Perform maintenance safely

## Prepare The Work Area

Choose a clean, level work area. Make sure you have sufficient room. Check clearances. Make certain there is adequate light and ventilation. Clean the walking and working surfaces. Remove oil, grease, and water to eliminate slippery areas. Put sand or other absorbent material on slippery areas. (24)

**29  
RIGHT**



## Prepare Yourself

Wear all the protective clothing the job requires. Wear a rubber apron and rubber gloves when working with corrosive materials. Wear gloves and safety shoes when handling wooden blocks, wire rope or sharp-edged metal or heavy objects. Safety shoes must be worn at all times. (30)

Safety glasses, goggles or a face-shield are always needed for eye protection from electric arcs from shorts, fluids under pressure, while grinding, servicing batteries, and from flying debris or loose material when engine is running or tools are used. Wear a face-shield when you disassemble spring loaded components or work with battery acid. Wear a helmet or goggles with special lenses when you weld or cut with a torch.

**30  
RIGHT**



## Perform maintenance safely

Do not sand, grind, flame-cut, braze or weld without a NIOSH/MSHA approved respirator or appropriate ventilation. If welding is required on this machine, refer to the manufacturer's manuals or consult your equipment dealer for proper procedures including welder certification requirements, proper grounding procedures and disconnecting of alternator or battery.

**Block the boom or purge the cylinders of all air when doing maintenance to prevent free fall.**



**31  
RIGHT**

Handle tools and heavy parts **CAREFULLY**—with regard for yourself and other persons. **LOWER ITEMS—DON'T DROP THEM.** (31)



**WARNING:** Keep clear of all rotating components. Wrapping or entanglement may result in serious injury or death. **KEEP HANDS—AND CLOTHING—AWAY FROM ALL MOVING PARTS.** Don't tempt fate with dangling ties, loose sleeves, rings or long hair. Keep pockets free of all objects which could fall out—and into machinery. (32)



**32  
WRONG**

Protect yourself with the proper equipment.

# Perform maintenance safely

## Prepare The Machine



**WARNING:** START THE ENGINE FROM THE DRIVER'S SEAT ONLY. NEVER ATTEMPT TO START THE ENGINE BY SHORTING ACROSS STARTER TERMINALS OR REACHING FROM THE GROUND OR OUTSIDE THE CAB. It may start in gear if neutral-start circuitry is bypassed. This could cause the unit to move suddenly and cause serious injury or death to anyone in its path. Move the machine onto a level surface. Stop engine, release all hydraulic pressure. Attach the cylinder rod support struts or block all hydraulically operated components if they must be in a raised position.



**WARNING:** DO NOT DISCONNECT HYDRAULIC COMPONENTS WHEN THERE IS PRESSURE IN THE SYSTEM. Disconnecting pressurized hose can result in serious injury to the exposed, unprotected face or other parts of your body. (33)

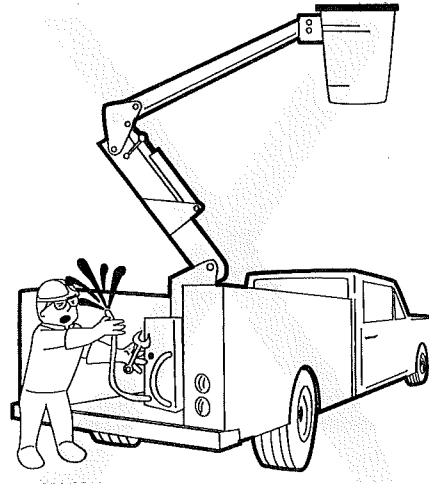

**33  
WRONG**

## Perform maintenance safely



**WARNING:** Never work on machinery with the engine running unless so instructed for specific service, by the manufacturer's operator's or service manuals.



**WARNING:** Never operate any type of engine without proper ventilation—EXHAUST FUMES KILL. (34)

If it is necessary to run an engine in an enclosed area, remove the exhaust fumes from the area with an exhaust pipe extension. If you do not have an exhaust pipe extension, make sure you open the doors and get outside air into the area. If adjustments must be made with the engine running, always work as a two-person team with one person sitting in the driver's seat while the other works on the machine. Remove only guards or covers that provide access. Wipe away excess grease and oil. Never leave guards off or access doors open when unattended. Keep bystanders away if access doors are open. Make certain all guards, screens or panels, and safety signs are reinstalled on the machine as recommended by the manufacturer.

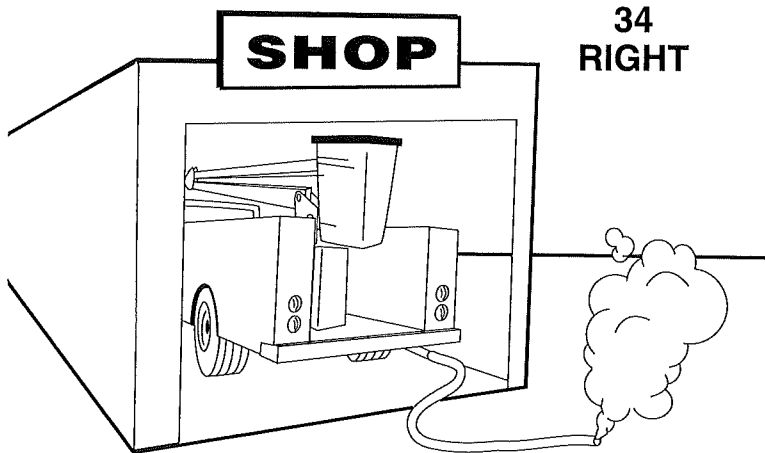

Exhaust fumes kill.

## Perform maintenance safely



**WARNING:** Never substitute a conductive wire braid type hose for any insulated or nonconductive hose. Death or serious injury will result from the bridging of an insulated gap with a conductive hose. Most nonconductive hoses are orange in color and are marked as "nonconductive". Hoses must not have pinhole perforations, bubbles or cuts.

### Insulated Test

Test the liner and insulated boom section(s) of your aerial device regularly per ANSI's A92 (A92.2) latest revision. (Periodic/Maintenance Test Procedures). (35)



**WARNING:** When hose, oil or other components that pass through the insulated section of the boom(s) are replaced, an electrical insulation test must be performed.

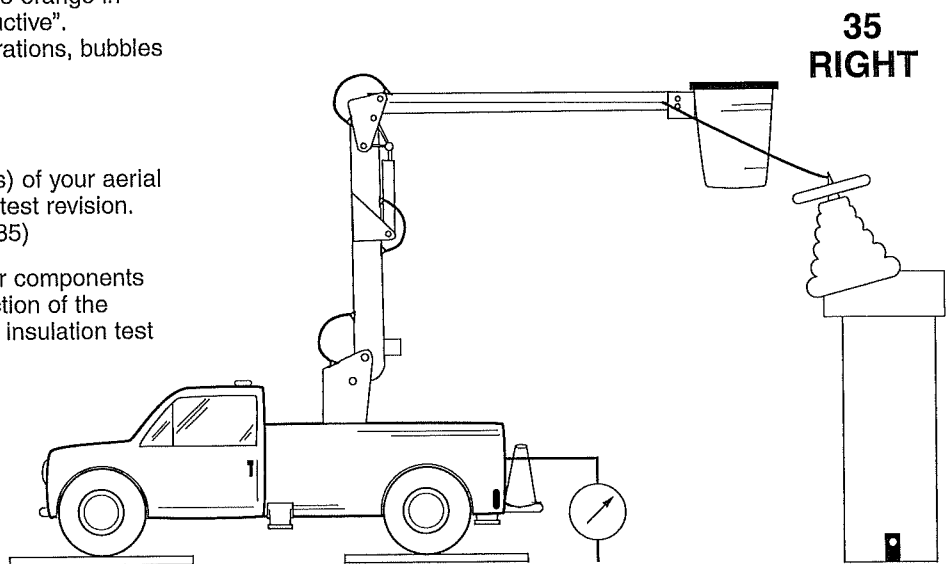

# Perform maintenance safely

## Use Jacks And Hoists Carefully

If you must work beneath a raised vehicle during disassembly or maintenance, always use a truck lift or use wood (NOT CONCRETE) blocks, jack-stands or other rigid and stable supports to brace all movable portions of the aerial device. If these steps are not taken, components may shift or move during disassembly which could cause pinching or crushing injuries. When using jacks and hoists always be sure they are adequately supported. (36)



**WARNING:** Never use concrete blocks for supports. They can collapse even under light loads. Make sure the hoist or jacks you use are in good repair. Never use jacks with cracked, bent or twisted parts. Never use frayed, twisted or pinched cables. Never use bent or distorted hooks.

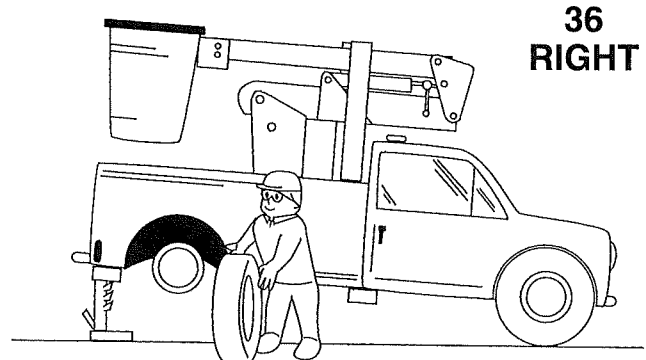

Use jacks and hoists carefully.

# Perform maintenance safely

## Avoid Electrical System Hazards

Disconnect the battery before working on the electrical system. Remove the ground cables first. When reconnecting the battery, reconnect the ground cable last. Never work on the electrical system unless you are thoroughly familiar with system details and the special handling required. (37)

**37  
WRONG**



## Brake Safety Tips

Always follow manufacturer's manual(s) when adjusting brakes. Improperly adjusted brakes can cause an accident. Block wheels before purging air from the brake system. Air trapped in brake lines can cause erratic performance or loss of brakes.

Use only brake fluid recommended by manufacturer.

## Be Careful With Fluids Under Pressure

The hydraulic system may be under pressure whenever the engine is running and may hold pressure even after shutdown. Install cylinder rod support struts or block the cylinders and equipment securely before working on the hydraulic system. Cycle all hydraulic steering and other controls after shutdown to relieve system pressure. When venting or filling the hydraulic system, loosen the filler cap slowly and remove it gradually. If the system is equipped with an accumulator, see the manufacturer's service manual for discharge and recharge instructions. Do not permit an open flame around the hydraulic system. Clean up spilled fluid immediately.

## Perform maintenance safely



**WARNING:** Diesel fuel or hydraulic fluid under pressure can penetrate the skin or eyes and cause serious injury, blindness or death. Fluid leaks under pressure may not be visible. Use a piece of cardboard or wood to find leaks but do not use your bare hand. Wear a face shield or safety goggles for eye protection. If any fluid is injected into the skin, it must be surgically removed within a few hours by a doctor familiar with this type of injury. (38)

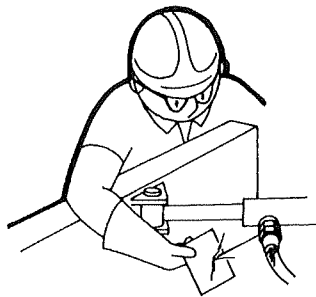

**38  
RIGHT**

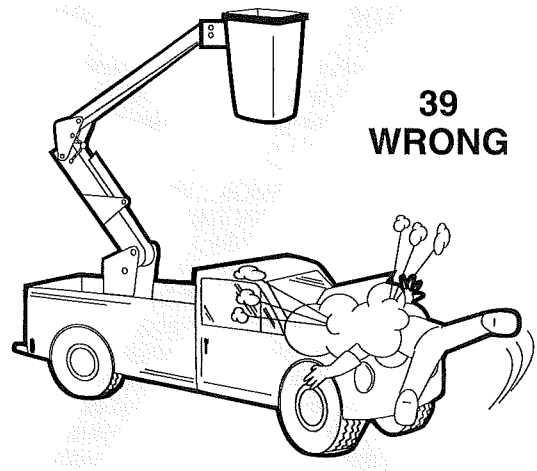

**39  
WRONG**

### Be Careful With Hot Cooling Systems



**WARNING:** Liquid cooling systems build up pressure as the engine gets hot. Before removing the radiator cap, stop the engine and let the system cool. Remove the radiator cap only after the coolant is cold. For cooling systems with an overflow tank, the coolant can usually be checked at the tank without removal of the radiator cap. See manufacturer's instructions. (39)

Pressurized fluid can cause injuries.

# Perform maintenance safely

## Avoid Fire And Explosion Hazards

Stop the engine and shut off electrical equipment while filling the fuel tank. Use extra caution when fueling a hot engine. Always ground the fuel nozzle against the filler neck to avoid sparks.



**WARNING:** NEVER SMOKE WHILE HANDLING FUEL OR WORKING ON THE FUEL SYSTEM. THE FUMES IN AN EMPTY FUEL CONTAINER ARE EXPLOSIVE, NEVER CUT OR WELD ON FUEL LINES, TANKS OR CONTAINERS. Handle all solvents and dry chemicals according to procedures identified on manufacturer's containers or MSDS bar material. Work in a well-ventilated area. Make sure you know where fire extinguishers are kept and how to use them. Remove all trash or debris from the vehicle. Make sure that oily rags or other flammable material are removed from the machine. Check for fuel, oil or hydraulic fluid leaks. Repair the leaks and clean the machine before you operate.

Ether is flammable. Do not smoke when using Ether. Always follow the instructions on the Ether can and in the manufacturer's manual(s) for your machine. Do not use Ether if the engine is equipped with a glow plug or other type of preheater. Always use a nonflammable solvent when you clean parts. Do not use gasoline, diesel fuel or other flammable fluids. (40) Store all flammable fluids and material away from your work area in suitable containers, as per local regulations. Do not store flammable fluid or gas containers in compartments with electrical controls. Check readiness of fire extinguishers.

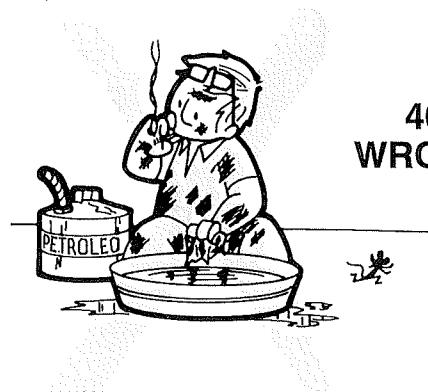

# Perform maintenance safely

## Avoid Battery Hazards

 **WARNING:** Lead-acid batteries contain sulfuric acid which can damage eyes or skin on contact. Always wear a face shield to avoid acid in eyes. If acid contacts eyes, flush immediately with clean water and get medical attention. Wear rubber gloves and protective clothing to keep acid off skin. If acid contacts skin, wash off immediately with clean water, then seek medical attention.

 **WARNING:** Lead-acid batteries produce flammable and explosive gases. Keep arcs, sparks, flames and lighted tobacco away. Use flashlight to check battery electrolyte level. Always check with engine stopped.

Do not charge a battery or jump-start the engine if the battery is frozen. Warm to 60°F (15°C) or the battery may explode. (41)

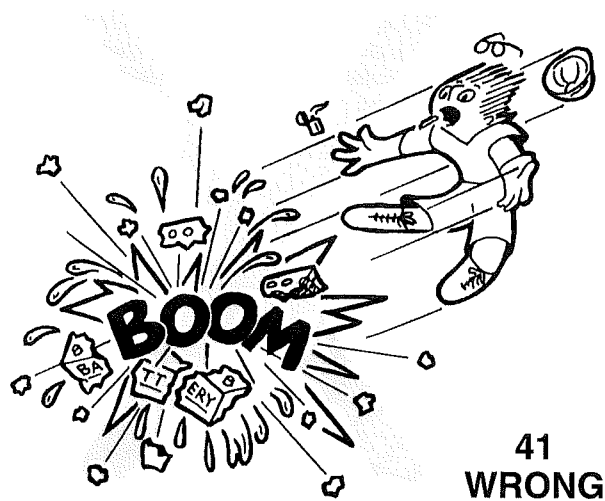

Use care when servicing batteries.

# Perform maintenance safely

## Tire Maintenance



**WARNING:** Explosive separation of a tire and/or rim parts can cause serious injury or death. Always follow the manufacturer's recommendations or see your tire supplier.



42  
**WRONG**

Special tools and procedures are required to change truck tires. To do it safely, it must be done correctly. Follow the step-by-step instructions given in a tire repair manual. Changing tires is a job better done by your tire service company. (42) Always maintain the correct tire pressure. Do not inflate the tires above the recommended pressure. Be sure to replace tire ballast if machine is so equipped. See manufacturer's specifications for ballast requirements. Inspect tires and wheels daily. Do not operate with low pressure, cuts, bubbles, damaged rims or missing lug bolts or nuts. Never cut or weld on the rim or rim parts. This could cause explosive decompression. If the tires are filled with nitrogen Do NOT add air. Fill only with dry nitrogen, using proper inflating equipment. Keep wheel lug nuts tightened to manufacturer's recommendations. A rise in tire pressure is normal during operation. It should NOT be reduced. When adjusting tire pressure, do so from a distance. Use a long hose with self-attaching chuck. Always stand behind tread when adjusting tire pressure.

# Perform maintenance safely

## Tire Repair

Tires are to be repaired only by a qualified individual using the proper procedures and safety equipment.



**WARNING:** Always use a safety cage or cable restraints when reinflating a repaired tire. (43)

## Air Reservoir Tank

Drain tank (if so equipped) daily. In cold weather, it is especially important that the air tank(s) be thoroughly drained at least once per shift. Be sure drain is closed before starting engine.

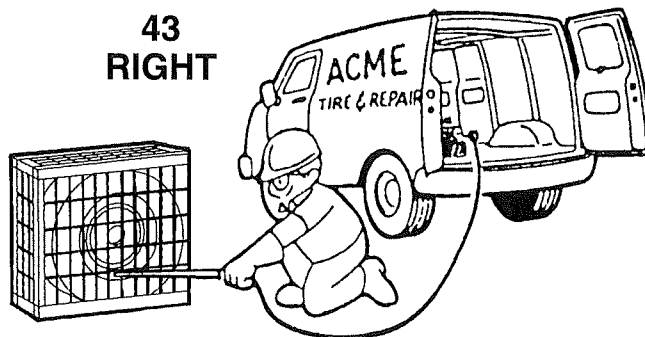

Tire repair is for qualified personnel only.

## Perform maintenance safely

### Complete Service And Repairs Before Machine Is Operated (44)

Tighten all bolts, fittings, and connections to torques specified by the manufacturer. Install all guards, covers, and shields after servicing. Replace or repair any damaged ones. Refill and recharge pressure systems only with manufacturer approved or recommended fluids.

Start the engine and check for leaks. (See hydraulic fluid warning, page 40.) Operate all controls to make sure machine is functioning properly. Cycle the boom, swing and outrigger controls several times to be sure cylinders are fully charged with oil. Road test machine if necessary. After testing, shut down, check the work you performed (any missing cotter pins, washers, locknuts, etc.). Recheck all fluid levels before releasing machine for operation.

Inspect all parts during repair and replace if cracked or damaged. Excessively worn or damaged parts can fail and cause injury or death. Replace any damaged or illegible decals.



**WARNING:** When hose, oil or other components that pass through the insulated section of the boom(s) are replaced, an electrical insulation test must be performed. (See page 38, Insulated Test)

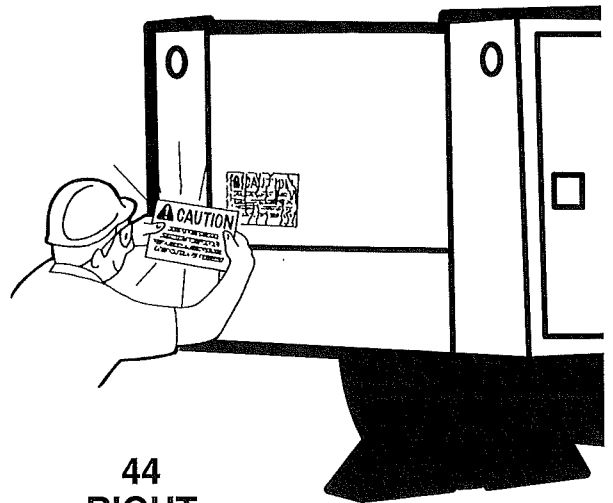

**44  
RIGHT**

## Test Your Knowledge

Now that you have read this safety manual, do you understand...

- Your safety program?
- Your machine manufacturer's manual(s)?
- Proper clothing and personal safety equipment?
- Your machine's controls, warning signs, devices, and safety equipment?
- How to properly inspect, mount, and start your machine?
- How to check your machine for proper operation?
- Your work area and any special hazards that may exist?
- Proper operating procedures?
- Operating safety precautions?
- Under what conditions should you not operate your machine?
- Proper parking, shutdown, and dismounting procedures?
- Proper maintenance procedures?



## A Final Word to the User

You have just finished reading the AEM Aerial Device Safety Manual. It is impossible for this manual to cover every safety situation that you may encounter on a daily basis. Your knowledge of these safety precautions and your application to the basic rules of safety will help to build good judgment in all situations. Our objective is to help you develop, establish, and maintain good safety habits to make operating an aerial device easier and safer for you.

**Many pictorials in this safety manual can be downloaded at <http://pictorials.aem.org>.  
For additional publications, visit our website at [www.safetymaterials.org](http://www.safetymaterials.org).**



**Association of  
Equipment Manufacturers**

e-mail [safetymaterials@aem.org](mailto:safetymaterials@aem.org)  
[www.aem.org](http://www.aem.org)

This manual is one in a series on the safe operation of machinery, published by AEM.

ISBN 978-1-937029-26-5



90000>

9 781937 029265

To order AEM safety materials  
visit [www.safetymaterials.org](http://www.safetymaterials.org).



FORM AD9-98

Printed in U.S.A.